



## Finite gap Jacobi matrices: An announcement

Jacob S. Christiansen, Barry Simon\*, Maxim Zinchenko

Mathematics 253-37, California Institute of Technology, Pasadena, CA 91125, United States

### ARTICLE INFO

#### Article history:

Received 23 October 2007

#### MSC:

primary : 47B36  
42C05  
secondary : 47A10  
30F35

#### Keywords:

Finite gap Jacobi matrices  
Isospectral torus  
Szegő's theorem  
Szegő asymptotics  
Jost function

### ABSTRACT

We consider Jacobi matrices whose essential spectrum is a finite union of closed intervals. We focus on Szegő's theorem, Jost solutions, and Szegő asymptotics for this situation. This announcement describes talks the authors gave at OPSFA 2007.

© 2009 Elsevier B.V. All rights reserved.

### 1. Introduction and background

This paper announces results in the spectral theory of orthogonal polynomials on the real line (OPRL). We start out with a measure  $d\mu$  of compact support on  $\mathbb{R}$ ;  $P_n(x; d\mu)$  (sometimes we drop  $d\mu$ ) and  $p_n(x; d\mu)$  are the monic orthogonal and orthonormal polynomials, and  $\{a_n, b_n\}_{n=1}^{\infty}$  the Jacobi parameters determined by the recursion relations (where  $p_{-1} = 0$ ):

$$xp_n(x) = a_{n+1}p_{n+1}(x) + b_{n+1}p_n(x) + a_np_{n-1}(x) \quad (1.1)$$

summarized in a Jacobi matrix

$$J = \begin{pmatrix} b_1 & a_1 & 0 & 0 & \cdots \\ a_1 & b_2 & a_2 & 0 & \cdots \\ 0 & a_2 & b_3 & a_3 & \cdots \\ \vdots & \vdots & \vdots & \vdots & \ddots \end{pmatrix}. \quad (1.2)$$

We will use the Lebesgue decomposition of  $d\mu$ ,

$$d\mu(x) = w(x) dx + d\mu_s(x) \quad (1.3)$$

with  $d\mu_s$  singular w.r.t.  $dx$ .

In this introduction, we will also consider orthogonal polynomials on the unit circle (OPUC) where  $d\mu$  is now a measure on  $\partial\mathbb{D} = \{e^{i\theta} \mid \theta \in [0, 2\pi)\}$ ;  $\Phi_n(z; d\mu)$  and  $\varphi_n(z; d\mu)$  are the monic orthogonal and orthonormal polynomials, and

$$\alpha_n = -\overline{\Phi_{n+1}(0)} \quad (1.4)$$

\* Corresponding author.

E-mail addresses: [stordal@caltech.edu](mailto:stordal@caltech.edu) (J.S. Christiansen), [bsimon@caltech.edu](mailto:bsimon@caltech.edu) (B. Simon), [maxim@caltech.edu](mailto:maxim@caltech.edu) (M. Zinchenko).

are the Verblunsky coefficients. (1.3) is replaced by

$$d\mu(\theta) = w(\theta) \frac{d\theta}{2\pi} + d\mu_s(\theta). \tag{1.5}$$

We have  $|\alpha_n| < 1$  and  $\rho_n$  is defined by

$$\rho_n = (1 - |\alpha_n|^2)^{1/2}. \tag{1.6}$$

For background on OPRL, see [1–4], and for OPUC, see [1,5–7].

Our starting point is Szegő’s theorem in Verblunsky’s form (see Ch. 2 of [6] for history and proof):

**Theorem 1.1.** Consider OPUC. The following are equivalent:

$$(a) \quad \int \log(w(\theta)) \frac{d\theta}{2\pi} > -\infty \tag{1.7}$$

$$(b) \quad \sum_{n=0}^{\infty} |\alpha_n|^2 < \infty \tag{1.8}$$

$$(c) \quad \prod_{n=0}^{\infty} \rho_n > 0. \tag{1.9}$$

Of course, (b)  $\Leftrightarrow$  (c) is trivial and (c) is not normally included. We include it because for OPRL, (a)  $\Leftrightarrow$  (c) and (a)  $\Leftrightarrow$  (b) have different analogs. The analog of (a)  $\Leftrightarrow$  (c) for OPRL on  $[-2, 2]$ , which we will call Szegő’s theorem for  $[-2, 2]$ , is:

**Theorem 1.2.** Let  $J$  be a Jacobi matrix with  $\sigma_{\text{ess}}(J) = [-2, 2]$  and eigenvalues  $\{E_j\}_{j=1}^N$  in  $\sigma(J) \setminus [-2, 2]$ .

Suppose that

$$\sum_{j=1}^N (|E_j| - 2)^{1/2} < \infty. \tag{1.10}$$

Then the following are equivalent:

$$(i) \quad \int_{-2}^2 (4 - x^2)^{-1/2} \log(w(x)) \, dx > -\infty \tag{1.11}$$

$$(ii) \quad \limsup a_1 \dots a_n > 0. \tag{1.12}$$

If these hold, then

$$\lim_{n \rightarrow \infty} a_1 \dots a_n \tag{1.13}$$

exists in  $(0, \infty)$ .

**Remarks.** 1. For a proof and history, see Sect. 13.8 and Theorem 13.8.9 of [7]

2. The number of eigenvalues,  $N$ , can be zero, finite, or infinite.

3. There are also results that imply (1.10). For example, if (1.11) holds, and the  $\limsup$  in (1.12) is finite, then (1.10) holds.

4. (1.12) involves  $\limsup$ , not  $\liminf$ ; its converse is that  $a_1 \dots a_n \rightarrow 0$ .

The analog of (a)  $\Leftrightarrow$  (b) is the following result of Killip–Simon [8]:

**Theorem 1.3.** Let  $J$  be a Jacobi matrix with  $\sigma_{\text{ess}}(J) = [-2, 2]$  and eigenvalues  $\{E_j\}_{j=1}^N$  in  $\sigma(J) \setminus [-2, 2]$ . Then

$$\sum_{n=1}^{\infty} b_n^2 + (a_n - 1)^2 < \infty \tag{1.14}$$

if and only if the following both hold:

$$(i) \quad \sum_{j=1}^N (|E_j| - 2)^{3/2} < \infty \tag{1.15}$$

$$(ii) \quad \int_{-2}^2 (4 - x^2)^{1/2} \log(w(x)) \, dx > -\infty. \tag{1.16}$$

The last two theorems involve perturbations of the Jacobi matrix with  $b_n \equiv 0, a_n \equiv 1$ , essentially up to scaling and translation, constant  $b_n, a_n$ . The next simplest situation is perturbations of periodic Jacobi matrices, that is,  $J_0$  has Jacobi parameters  $\{a_n^{(0)}, b_n^{(0)}\}_{n=1}^\infty$  obeying

$$a_{n+p}^{(0)} = a_n^{(0)} \quad b_{n+p}^{(0)} = b_n^{(0)} \tag{1.17}$$

for some fixed  $p$  and all  $n = 1, 2, \dots$ . In that case, we have a set

$$\epsilon = \bigcup_{j=1}^{\ell+1} \epsilon_j$$

where  $\{\epsilon_j\}_{j=1}^{\ell+1}$  are  $\ell + 1$  disjoint closed intervals

$$\begin{aligned} \epsilon_j &= [\alpha_j, \beta_j] \\ \alpha_1 &< \beta_1 < \alpha_2 < \beta_2 < \dots < \alpha_{\ell+1} < \beta_{\ell+1} \end{aligned}$$

with  $\ell$  gaps  $(\beta_1, \alpha_2), \dots, (\beta_\ell, \alpha_{\ell+1})$ , and

$$\sigma_{\text{ess}}(J_0) = \epsilon. \tag{1.18}$$

We always have  $\ell + 1 \leq p$  and generically  $\ell + 1 = p$ . In this generic case, we say “all gaps are open.” We use  $\ell$ , the number of gaps, because  $J_0$  is not the only periodic Jacobi matrix obeying (1.18)—there is an  $\ell$ -dimensional manifold,  $\mathcal{T}_\epsilon$ , of periodic  $J_0$ 's obeying (1.18). Indeed, the collection of all  $\{a_j^{(0)}, b_j^{(0)}\}_{j=1}^p \subset [(0, \infty) \times \mathbb{R}]^p$  obeying (1.18) for fixed  $\epsilon$  is an  $\ell$ -dimensional torus, so  $\mathcal{T}_\epsilon$  is called the isospectral torus; see [4, Chap. 5]. That the key to extending Theorems 1.2 and 1.3 to the periodic case is an approach to an isospectral torus is an idea of Simon [7].

Damanik, Killip, and Simon [9] have proven the following analogs of Theorems 1.2 and 1.3:

**Theorem 1.4.** *Let  $\epsilon$  be the essential spectrum of a periodic  $J_0$  and let  $J$  be a Jacobi matrix with*

$$\sigma_{\text{ess}}(J) = \epsilon.$$

*Let  $\{E_j\}_{j=1}^N$  be the eigenvalues of  $J$  in  $\sigma(J) \setminus \epsilon$ . Suppose that*

$$\sum_{j=1}^N \text{dist}(E_j, \epsilon)^{1/2} < \infty. \tag{1.19}$$

*Then the following are equivalent:*

$$(i) \quad \int_\epsilon \text{dist}(x, \mathbb{R} \setminus \epsilon)^{-1/2} \log(w(x)) \, dx > -\infty \tag{1.20}$$

$$(ii) \quad \limsup \frac{a_1 \dots a_n}{C(\epsilon)^n} > 0. \tag{1.21}$$

**Remarks.** 1. In (1.21),  $C(\epsilon)$  is the logarithmic capacity of  $\epsilon$ ; see [10–12] for a discussion of potential theory.

2. Damanik–Killip–Simon [9] do not use (1.21) but instead

$$\limsup \frac{a_1 \dots a_n}{a_1^{(0)} \dots a_n^{(0)}} > 0.$$

Since  $a_1^{(0)} \dots a_p^{(0)} = C(\epsilon)^p$ , this is equivalent.

**Theorem 1.5.** *Let  $J_0$  be a periodic Jacobi matrix with all gaps open and essential spectrum  $\epsilon$ . Let  $J$  be a Jacobi matrix with*

$$\sigma_{\text{ess}}(J) = \epsilon.$$

*Let  $\{E_j\}_{j=1}^N$  be the eigenvalues of  $J$  in  $\sigma(J) \setminus \epsilon$ . Define*

$$d_m(\{a_n, b_n\}_{n=1}^\infty, \{a'_n, b'_n\}_{n=1}^\infty) = \sum_{j=0}^\infty e^{-j} [ |a_{m+j} - a'_{m+j}| + |b_{m+j} - b'_{m+j}| ] \tag{1.22}$$

and

$$d_m(\{a_n, b_n\}, \mathcal{T}_\epsilon) = \min_{(a', b') \subset \mathcal{T}_\epsilon} d_m(\{a_n, b_n\}, \{a'_n, b'_n\}). \tag{1.23}$$

Then

$$\sum_{m=1}^{\infty} d_m(\{a_n, b_n\}, \mathcal{T}_\epsilon)^2 < \infty$$

if and only if

$$(i) \quad \sum_{j=1}^N \text{dist}(E_j, \epsilon)^{3/2} < \infty \tag{1.24}$$

$$(ii) \quad \int_{\epsilon} \text{dist}(x, \mathbb{R} \setminus \epsilon)^{1/2} \log(w(x)) \, dx > -\infty. \tag{1.25}$$

While these last two theorems are fairly complete from the point of view of perturbations of periodic Jacobi matrices, they are incomplete from the point of view of sets  $\epsilon$ . By harmonic measure on  $\epsilon$ , we mean the potential theoretic equilibrium measure. It is known (Aptekarev [13]; see also [14,15,4]) that

- (i)  $\epsilon$  is the essential spectrum of a periodic Jacobi matrix if and only if the harmonic measure of each  $\epsilon_j$  is rational. **Theorem 1.4** is limited to this case.
- (ii) All gaps are open if and only if each  $\epsilon_j$  has harmonic measure  $1/p$ . **Theorem 1.5** is limited to this case.

Our major focus in this work is what happens for a general finite gap set  $\epsilon$  in which the harmonic measures are not necessarily rational. This is an announcement. We plan at least two fuller papers, one [16] on the structure of the isospectral torus and one [17] on Szegő’s theorem.

## 2. Main results

There are two main results in [17]. The following is partly new:

**Theorem 2.1.** *Suppose  $\epsilon$  is an arbitrary finite gap set*

$$\epsilon = \bigcup_{j=1}^{\ell+1} [\alpha_j, \beta_j]$$

$$\alpha_1 < \beta_1 < \alpha_2 < \dots < \beta_{\ell+1}.$$

Let  $J$  be a Jacobi matrix with

$$\sigma_{\text{ess}}(J) = \epsilon \tag{2.1}$$

and let  $\{E_j\}_{j=1}^N$  be the eigenvalues of  $J$  in  $\sigma(J) \setminus \epsilon$ . Suppose that

$$\sum_{j=1}^N \text{dist}(E_j, \epsilon)^{1/2} < \infty. \tag{2.2}$$

Then the following are equivalent:

$$(i) \quad \int_{\epsilon} \text{dist}(x, \mathbb{R} \setminus \epsilon)^{-1/2} \log(w(x)) \, dx > -\infty \tag{2.3}$$

$$(ii) \quad \limsup \frac{a_1 \dots a_n}{C(\epsilon)^n} > 0. \tag{2.4}$$

That (i) + (2.2)  $\Rightarrow$  (ii) is not new. When  $N = 0$  (i.e., no bound states), (i)  $\Rightarrow$  (ii) goes back to Widom [18], following earlier partial results of Akhiezer and Tomčuk [19–21]. Peherstorfer–Yuditskii [22] proved (i)  $\Rightarrow$  (ii) under a condition on the bound states, which after a query from Damanik–Killip–Simon, Peherstorfer–Yuditskii improved to (2.2) and posted on the arXiv [23]. Thus, the new element of **Theorem 2.1** is the converse direction (ii) + (2.2)  $\Rightarrow$  (i).

Associated to each such  $\epsilon$  is a natural isospectral torus: certain almost periodic Jacobi matrices that lie in an  $\ell$ -dimensional torus. Although the torus,  $\mathcal{T}_\epsilon$ , has been studied before (e.g., [18] or [24]), many features are not explicit in the literature, so we wrote [16].

We will need the proper analog of the “Jost function” for this situation. It involves the potential theorist’s Green’s function for  $\epsilon$ ,  $G_\epsilon$ , the unique function harmonic on  $\mathbb{C} \setminus \epsilon$ , with zero boundary values on  $\epsilon$  and with  $G_\epsilon(z) = \log |z| + O(1)$  near infinity. We let  $d\rho_\epsilon$  be the equilibrium measure for  $\epsilon$  with density  $\rho_\epsilon(x)$  with respect to the Lebesgue measure and define  $u(0; J)$  by

$$u(0; J) = \prod_{j=1}^N \exp(-G_\epsilon(E_j)) \exp\left(-\frac{1}{2} \int_{\epsilon} \log\left(\frac{w(x)}{\rho_\epsilon(x)}\right) d\rho_\epsilon(x)\right). \tag{2.5}$$

We note that since  $\rho_\epsilon(x) \sim \text{dist}(x, \mathbb{R} \setminus \epsilon)^{-1/2}$ , the Szegő condition (2.3) implies the convergence of the integral in (2.5), and since on  $\mathbb{R} \setminus \epsilon$ ,  $G_\epsilon(x)$  vanishes as  $\text{dist}(x, \epsilon)^{1/2}$  as  $x \rightarrow \epsilon$ , (2.2) implies convergence of the product in (2.5).

The other main result is the following:

**Theorem 2.2.** *Suppose  $J$  is a Jacobi matrix obeying the conditions (2.1)–(2.4) in  $\epsilon$ . Then there is a point  $J_\infty = \{a_n^{(\infty)}, b_n^{(\infty)}\}_{n=1}^\infty \in \mathcal{T}_\epsilon$  so*

$$|a_n - a_n^{(\infty)}| + |b_n - b_n^{(\infty)}| \rightarrow 0 \tag{2.6}$$

as  $n \rightarrow \infty$ . Moreover,  $a_1 \dots a_n / C(\epsilon)^n$  is asymptotically almost periodic. Indeed,

$$\frac{a_1 \dots a_n}{a_1^{(\infty)} \dots a_n^{(\infty)}} \rightarrow \frac{u(0; J_\infty)}{u(0; J)}. \tag{2.7}$$

More generally, if  $d\mu^{(\infty)}$  is the spectral measure for  $J_\infty$ , we have that for  $x \in \mathbb{C} \setminus \epsilon$ ,

$$\frac{p_n(x, d\mu)}{p_n(x, d\mu^{(\infty)})} \tag{2.8}$$

has a limit.

**Remarks.** 1. It is an interesting calculation to check that (2.7) holds for  $\epsilon = [-2, 2]$  based on the formulas in [8] (see (1.29)–(1.31) of that paper).

2. The limit in (2.8) can also be described in terms of a suitable “Jost function”  $u$ .

When there are no bound states (i.e.,  $N = 0$ ), this is a result of Widom [18]. Peherstorfer–Yuditskii [22] found a different proof relying on a machinery of Sodin–Yuditskii [24] which allowed some bound states, and their note [23] extended to (2.2). So this theorem is not new—what is new is our proof of it and the compact form of (2.7) is new.

One application that Killip–Simon [8] make of Theorem 1.2 is to prove a conjecture of Nevai [25] that

$$\sum_{n=1}^\infty |a_n - 1| + |b_n| < \infty \tag{2.9}$$

implies (1.11). For (2.9) implies (1.12) and a result of Hundertmark–Simon [26] says (2.9) implies (1.10). Damanik–Killip–Simon [9] used Theorem 1.4 and a matrix version of [26] to prove an analog of Nevai’s conjecture for perturbations of periodic Jacobi matrices. This leads us to:

**Conjecture 2.3.** *Suppose  $\{a_n^{(\infty)}, b_n^{(\infty)}\}_{n=1}^\infty$  lies in  $\mathcal{T}_\epsilon$  and  $J$  is a Jacobi matrix obeying*

$$\sum_{n=1}^\infty |a_n - a_n^{(\infty)}| + |b_n - b_n^{(\infty)}| < \infty. \tag{2.10}$$

Then the Szegő condition, (2.3), holds.

The issue is whether (2.10) implies (2.2). That it holds for the eigenvalues above and below the spectrum is a result of Frank–Simon–Weidl [27], but it remains unknown for eigenvalues in the gaps. However, Hundertmark–Simon [28] showed that if for some  $\epsilon > 0$ ,

$$\sum_{n=1}^\infty [\log(n + 1)]^{1+\epsilon} [|a_n - a_n^{(\infty)}| + |b_n - b_n^{(\infty)}|] < \infty \tag{2.11}$$

then (2.2) holds. Thus, we have a corollary of Theorem 2.1:

**Corollary 2.4.** *If (2.11) holds for some  $\{a_n^{(\infty)}, b_n^{(\infty)}\} \in \mathcal{T}_\epsilon$ , then (2.3) holds.*

The big open question on which we are working is extending the Killip–Simon theorem (Theorem 1.3) to a general finite gap setting.

### 3. Covering maps and Beardon’s theorem

To understand the approach to the proofs we will discuss in this section and the next, we need to explain the machinery behind the proofs of Theorems 1.2–1.5. It goes back to the Szegő mapping ([29]; see [7, Sect. 13.1]) of OPRL problems on

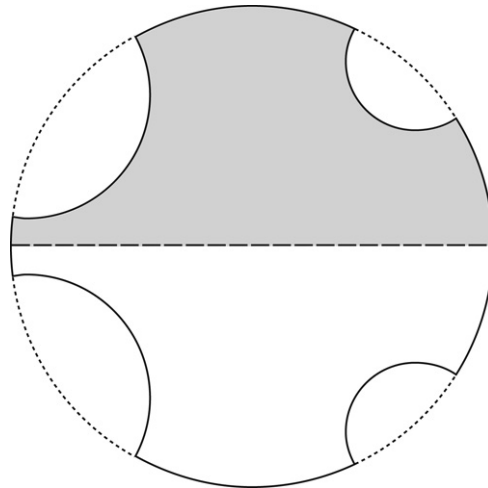

Fig. 1. The fundamental domain,  $\mathbb{F}$ .

$[-2, 2]$  to OPUC via  $x = 2 \cos \theta = z + z^{-1}$  if  $z = e^{i\theta}$ . It was realized by Peherstorfer–Yuditskii [30] and Killip–Simon [8] that while  $x = 2 \cos \theta$  will not work on the level of measures if there are mass points outside  $[-2, 2]$ , the map

$$x(z) = z + z^{-1} \tag{3.1}$$

allows one to drag

$$m(x) = \int \frac{d\mu(t)}{t - x} \tag{3.2}$$

back to  $\mathbb{D}$  and use function theory on the disk.

Following Sodin–Yuditskii [24], we can do something similar for finite gap situations.  $x(z)$  given by (3.1) is the unique analytic map of  $\mathbb{D}$  to  $(\mathbb{C} \setminus [-2, 2]) \cup \{\infty\}$  which is a bijection with  $x(0) = \infty$ ,  $\lim_{z \rightarrow 0} zx(z) > 0$ . If  $(\mathbb{C} \setminus [-2, 2]) \cup \{\infty\}$  is replaced by  $(\mathbb{C} \setminus \epsilon) \cup \{\infty\}$ , there is no map with these properties because  $(\mathbb{C} \setminus \epsilon) \cup \{\infty\}$  is not simply connected. Rather, its fundamental group,  $\pi_1$ , is isomorphic to  $F_\ell$ , the free non-abelian group on  $\ell$  generators. But if we demand that  $x$  be onto and only locally one-one, there is such a map.

For  $(\mathbb{C} \setminus \epsilon) \cup \{\infty\}$  has a universal covering space which is locally homeomorphic to  $(\mathbb{C} \setminus \epsilon) \cup \{\infty\}$  on which  $\pi_1$  acts. This local map can be used to give a unique holomorphic structure, that is, the universal cover is a Riemann surface and  $\pi_1$  acts as a set of biholomorphic bijections. The theory of uniformization (see [31]) implies the cover is the unit disk. Thus:

**Theorem 3.1.** *There is a unique holomorphic map of  $\mathbb{D}$  to  $(\mathbb{C} \setminus \epsilon) \cup \{\infty\}$  which is onto, locally one-one, with  $x(0) = \infty$  and  $\lim_{z \rightarrow 0} zx(z) > 0$ . Moreover, there is a group  $\Gamma$  of Möbius maps of  $\mathbb{D}$  onto  $\mathbb{D}$  so  $\Gamma \cong F_\ell$  and*

$$x(z) = x(w) \Leftrightarrow \exists \gamma \in \Gamma \text{ so that } \gamma(z) = w.$$

Thus,  $x$  is automorphic for  $\gamma$ , that is,  $x \circ \gamma = x$ . If one looks at  $x^{-1}[(\mathbb{C} \setminus [\alpha_1, \beta_{\ell+1}]) \cup \{\infty\}]$ , there is a unique connected inverse image containing 0, call it  $\mathbb{F}$ . This is  $\mathbb{D}$  with  $\ell$  orthodisks (i.e., disks whose boundary is orthogonal to  $\partial\mathbb{D}$ ) removed from the upper half-disk and their symmetric partners under complex conjugation (see Fig. 1: the shaded area is the inverse image of the lower half-plane).

Label the circles in the upper half-plane  $C_1^+, \dots, C_\ell^+$  going clockwise, and  $C_1^-, \dots, C_\ell^-$  the conjugate circles. Let  $\gamma_j^\pm$  be the composition of complex conjugation followed by inversion in  $C_j^\pm$ , so  $\gamma_j^\pm[\bar{\mathbb{F}}]$  lies inside the disk bounded by  $C_j^\pm$ .  $\Gamma$  consists of words in  $\{\gamma_j^\pm\}$ , that is, finite products of these elements with the rule that no  $\gamma_j^+$  is next to a  $\gamma_j^-$  (same  $j$ ) for  $(\gamma_j^+)^{-1} = \gamma_j^-$ . Thus,  $\Gamma = \{\text{id}\} \cup \Gamma^{(1)} \cup \dots$  where  $\Gamma^{(k)}$  has  $2\ell(2\ell - 1)^{k-1}$  elements, each a word of length  $k$ .

We define

$$\mathcal{R}_m = \partial\mathbb{D} \setminus \bigcup_{\gamma \in \{\text{id}\} \cup \dots \cup \Gamma^{(m-1)}} \gamma[\bar{\mathbb{F}}]. \tag{3.3}$$

Fig. 2 shows three levels of orthocircles.  $\mathcal{R}_3$  is the part of  $\partial\mathbb{D}$  inside the 36 small circles.

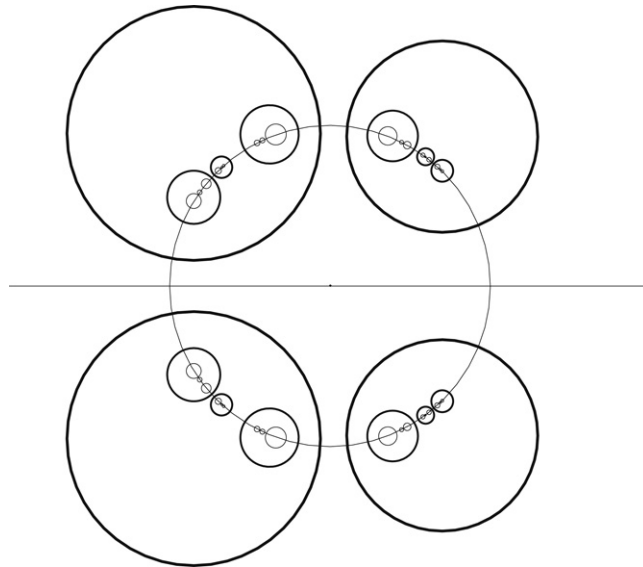

Fig. 2. Images of  $\mathbb{F}$  under words of length  $\leq 3$ .

In [32], Beardon proved the following theorem:

**Theorem 3.2.** *Let  $\Gamma$  be a finitely generated Fuchsian group so that the set of limit points of  $\{\gamma(0)\}_{\gamma \in \Gamma}$  is not all of  $\partial\mathbb{D}$ . Then there exists  $t < 1$  so that*

$$\sum_{\gamma \in \Gamma} |\gamma'(0)|^t < \infty. \tag{3.4}$$

The  $\Gamma$  associated to  $x$  is clearly finitely generated and points in  $\overline{\mathbb{F}} \cap \partial\mathbb{D}$  are not limit points, so Beardon’s theorem applies. ([4] has a simple proof of Beardon’s theorem for this special case of interest here.) In [17], we show, using some simple hyperbolic geometry, that (3.4) implies

**Corollary 3.3.** *Let  $|\cdot|$  be the Lebesgue measure on  $\partial\mathbb{D}$ . Then there exists  $A > 0$  and  $C$  so that*

$$|\mathcal{R}_m| \leq Ce^{-Am}. \tag{3.5}$$

(3.4) is known to be equivalent to

$$\sum_{\gamma \in \Gamma} (1 - |\gamma(z)|)^t < \infty \tag{3.6}$$

for all  $z \in \mathbb{D}$ . This result for  $t = 1$  (which goes back to Burnside [33]) implies the existence of the Blaschke product

$$B(z, z_0) = \prod_{\gamma \in \Gamma} b(z, \gamma(z_0)) \tag{3.7}$$

where

$$b(z, w) = -\frac{\bar{w}}{|w|} \frac{z - w}{1 - \bar{w}z} \tag{3.8}$$

if  $w \neq 0$  and  $b(z, 0) = z$ . In particular, we set

$$B(z) \equiv B(z, z_0 = 0).$$

$B$  is related to the Green’s function  $G_c$ : we have

$$|B(z)| = \exp(-G_c(x(z))) \tag{3.9}$$

as can be seen by noting the right side behaves like  $C|z|$  near  $z = 0$  and (3.9) holds for  $z \in \partial\mathbb{D}$ .

#### 4. MH representation and Szegő's theorem

Simon–Zlatoš [34] and Simon [35] provided some simplifications of Killip–Simon [8] and, in particular, [35] stated a representation theorem for meromorphic Herglotz (aka MH) functions. Variants of this representation theorem are behind parts of [9] and other applications of sum rules (e.g., Denisov [36]).

Our work also depends on such a representation theorem for automorphic meromorphic functions which obey  $\text{Im} f > 0$  on  $\mathbb{F} \cap \mathbb{C}^+$ . We prove the following:

**Theorem 4.1.** *Let  $M(z) = -m(x(z))$ , where  $m$  is the  $m$ -function (3.2) for some  $J$ , with  $\sigma_{\text{ess}}(J) = \epsilon$ . For  $R < 1$ , let  $B_R(z)$  be the product  $B(z, z_j)$  divided by  $B(z, p_j)$  for zeros and poles of  $M$  in  $\overline{\mathbb{F}}$  with  $\text{Im} z_j \geq 0$ ,  $\text{Im} p_j \geq 0$  and  $|z_j| < R$ ,  $|p_j| < R$ . Then, for  $z \in \mathbb{D}$ ,*

$$B_\infty(z) = \lim_{R \uparrow 1} B_R(z) \tag{4.1}$$

exists for  $z$  not a pole of  $M$ . Moreover, for a.e.  $\theta \in [0, 2\pi)$ ,  $M(e^{i\theta}) = \lim_{r \uparrow 1} M(re^{i\theta})$  exists,

$$\log |M(e^{i\theta})| \in \bigcap_{p < \infty} L^p \left( \partial\mathbb{D}, \frac{d\theta}{2\pi} \right) \tag{4.2}$$

and for  $z \in \mathbb{D}$ ,

$$a_1 M(z) = B(z) B_\infty(z) \exp \left( \frac{1}{2\pi} \int \frac{e^{i\theta} + z}{e^{i\theta} - z} \log |a_1 M(e^{i\theta})| d\theta \right). \tag{4.3}$$

In proving this, the big difference from the case considered in [35] is that there,  $\arg M(z) \in (0, \pi)$  in the upper half-disk. This and a similar estimate for  $B_\infty(z)$  prove that  $\arg(M(z)/B(z)B_\infty(z))$  is bounded. Here  $\arg M(z)$  is in  $(0, \pi)$  only on  $\mathbb{F} \cap \mathbb{C}_+$ . In general, if  $z \in \gamma[\mathbb{F}]$  where  $\gamma$  is a word of length  $n$  in  $\Gamma$  (written as a product of generators), then  $|\arg M(z)| \leq \pi(2n + 1)$ .  $\arg(M(z)/B_\infty(z)B(z))$  is not bounded. But by (3.5), the set where  $\arg(M(re^{i\theta})/B_\infty(re^{i\theta})B(re^{i\theta})) \geq 4\pi(n + 1)$  has size (in  $\theta$ ) bounded by  $Ce^{-An}$  uniformly in  $r$ . This still allows one to see  $\log(M(z)/B(z)B_\infty(z)) \in \bigcap_{p < \infty} H^p(\mathbb{D})$  and yields (4.3).

While there are some tricky points with eigenvalues in gaps, once one has Theorem 4.1, the proof of Theorem 2.1 follows the strategy used in [4] to prove the Szegő theorem for  $[-2, 2]$ . The potential theoretic equilibrium measures enter because one has:

**Proposition 4.2.** *If  $f$  is a nice function on  $\epsilon$ , then*

$$\int_{\partial\mathbb{D}} f(x(e^{i\theta})) \frac{d\theta}{2\pi} = \int_\epsilon f(x) d\rho_\epsilon(x). \tag{4.4}$$

**Remarks.** 1. Since  $\rho_\epsilon(x) \sim \text{dist}(x, \mathbb{R} \setminus \epsilon)^{-1/2}$ , this leads to Szegő conditions like (2.3).

2. It is well known how the equilibrium measure is transformed under conformal mappings (see, e.g., [37, Prop. 1.6.2]). (4.4) is a multi-valued variant of this result.

3. As will be discussed in [16], (3.9) is a special case of (4.4). In fact, one can show that they are actually equivalent.

**Sketch.** 1. One proves that

$$|B(z)| = \prod_{\gamma \in \Gamma} |\gamma(z)|. \tag{4.5}$$

2. On  $\partial\mathbb{D}$ ,  $(\partial \arg \gamma(e^{i\theta})/\partial\theta) > 0$ , so (4.5) implies

$$\sum_\gamma |\gamma'(e^{i\theta})| = \frac{d}{d\theta} \arg B(e^{i\theta}). \tag{4.6}$$

3. This implies

$$\int_{\partial\mathbb{D}} f(x(e^{i\theta})) \frac{d\theta}{2\pi} = \int_{\overline{\mathbb{F}} \cap \partial\mathbb{D}} f(x(e^{i\theta})) \frac{d \arg B}{d\theta} \frac{d\theta}{2\pi}. \tag{4.7}$$

4. Since  $x$  is two-one from  $\overline{\mathbb{F}} \cap \partial\mathbb{D}$  to  $\epsilon$ , this leads to

$$\text{LHS of (4.7)} = \int_\epsilon f(u) \frac{d \arg B(x^{-1}(u))}{du} \frac{du}{\pi}. \tag{4.8}$$



5. By a Cauchy–Riemann equation,

$$\frac{d \arg B(x^{-1}(u))}{du} = \frac{\partial \log |B(x^{-1}(u))|}{\partial n}$$

a normal derivative which is the normal derivative of the Green's function by (3.9).

6.

$$\frac{1}{\pi} \frac{\partial G_\epsilon}{\partial n}(x) dx = d\rho_\epsilon(x)$$

completing the proof.  $\square$

## 5. The Jost function and Jost solutions

Let  $J$  be a Jacobi matrix that obeys the hypotheses of Theorem 2.1, that is, (2.1)–(2.4) all hold. In that case, we say  $J$  is Szegő for  $\epsilon$ . For reasons that will become clear shortly, it is useful to define the *Jost function* on  $\mathbb{D}$  by

$$u(z, J) = \prod_{j=1}^N B(z, p_j) \exp\left(\frac{1}{4\pi} \int \frac{e^{i\theta} + z}{e^{i\theta} - z} \log\left(\frac{\rho_\epsilon(x(e^{i\theta}))}{w(x(e^{i\theta}))}\right) d\theta\right) \quad (5.1)$$

and the *Jost solution*,  $u_n(z, J)$ , for  $n \geq 0$  by (where  $a_0 \equiv 1$ )

$$u_n(z, J) = a_n^{-1} B(z)^n u(z, J^{(n)}) \quad (5.2)$$

where  $J^{(n)}$  is the  $n$  times stripped Jacobi matrix, that is, with Jacobi parameters  $\{a_j^{(n)}, b_j^{(n)}\}$  where

$$a_j^{(n)} = a_{j+n} \quad b_j^{(n)} = b_{j+n}. \quad (5.3)$$

Notice because of (2.2) and (2.3) the product and integral in (5.1) converge. Also notice (5.1) agrees with (2.5) given (3.9). For (5.2) to make sense, we need:

**Proposition 5.1.** *If  $J$  is Szegő for  $\epsilon$ , so is  $J^{(n)}$ .*

**Proof.** It is enough to prove it for  $n = 1$  and then use induction. (2.1) holds for  $J^{(1)}$  by Weyl's theorem and (2.2) by eigenvalue interlacing. (2.4) is trivial for  $J^{(1)}$  given it for  $J$ , and then (2.3) for  $J^{(1)}$  follows from Theorem 2.1.  $\square$

Here is the main result about Jost solutions:

**Theorem 5.2.** *Let  $J$  be Szegő for  $\epsilon$ . Then (with  $M_n(z) = M(z; J^{(n)})$ )*

$$(i) \quad a_{n+1} M_n(z) = B(z) \frac{u(z, J^{(n+1)})}{u(z, J^{(n)})} \quad (5.4)$$

$$(ii) \quad a_n M_n(z) = \frac{u_{n+1}(z, J)}{u_n(z, J)}. \quad (5.5)$$

(iii) For  $z \in \mathbb{D}$ ,  $u_n(z, J)$  obeys the difference equation ( $a_0 \equiv 1$ )

$$a_{n-1} u_{n-1} + b_n u_n + a_n u_{n+1} = x(z) u_n \quad (5.6)$$

for  $n \geq 1$ .

(iv) Up to a constant,  $u_n(z, J)$  is the unique  $\ell^2$  solution of (5.6).

**Sketch.** 1. (i) is just a restatement of (4.3) using the fact that

$$a_1^2 |M(e^{i\theta})|^2 = \frac{\operatorname{Im} M(e^{i\theta})}{\operatorname{Im} M_1(e^{i\theta})}. \quad (5.7)$$

2. (ii) follows from (i) and the definition (5.2).

3. (5.6) follows from (5.5) and the coefficient stripping formula for  $M$ , namely,

$$M_n(z)^{-1} = x(z) - b_{n+1} - a_{n+1}^2 M_{n+1}(z). \quad (5.8)$$

4. One proves uniform bounds on  $a_n^{-1}$  and  $u(z, J^{(n)})$ . Since  $|B(z)| < 1$  on  $\mathbb{D}$ ,  $u_n$  goes to zero exponentially and so lies in  $\ell^2$ . Uniqueness is standard.  $\square$

In [16,17], we study boundary values of  $u$  as  $z \rightarrow \partial\mathbb{D}$ , Green's functions, and related objects.

### 6. Character automorphic functions and asymptotics

The key fact in [Theorem 2.2](#) is the existence of the limit point in  $\mathcal{T}_\epsilon$ . The Jost function actually determines the limit point. To explain how, we need to discuss character automorphic functions.

If  $\gamma$  is a Möbius transformation of  $\mathbb{D}$  to  $\mathbb{D}$  and  $b$  is given by [\(3.8\)](#), then  $h(z) = b(\gamma(z), \gamma(w))$  has magnitude 1 on  $\partial\mathbb{D}$  and a zero only at  $z = w$ , so  $|h(z)| = |b(z, w)|$ , but there is generally a nontrivial phase factor (necessarily constant by analyticity). This implies that for any  $w \in \mathbb{D}$ ,

$$B(\gamma(z), w) = C_w(\gamma)B(z, w) \tag{6.1}$$

where  $|C_w(\gamma)| = 1$ . Clearly,  $C_w(\gamma\gamma') = C_w(\gamma)C_w(\gamma')$ , so  $C_w$  is a character of  $\Gamma$ , that is, a group homomorphism of  $\Gamma$  to  $\partial\mathbb{D}$ .

The set  $\Gamma^*$  of such homomorphisms is the dual group of  $\Gamma/[\Gamma, \Gamma] \cong \mathbb{Z}^\ell$ , so  $\Gamma^* \cong (\partial\mathbb{D})^\ell$  (cf. [38, Chap. III]). Essentially,  $C$  is uniquely determined by  $C(\gamma_j^+)$ ,  $j = 1, \dots, \ell$ .

A meromorphic function on  $\mathbb{D}$  obeying

$$f(\gamma(z)) = C(\gamma)f(z)$$

for all  $z \in \mathbb{D}$  and  $\gamma \in \Gamma$  is called *character automorphic*. [\(6.1\)](#) says Blaschke products are character automorphic. One can also see that if  $g$  is a real-valued function on  $\epsilon$ , then

$$f(z) = \exp\left(\int \frac{e^{i\theta} + z}{e^{i\theta} - z} \log(g(x(e^{i\theta}))) \frac{d\theta}{2\pi}\right) \tag{6.2}$$

is character automorphic, so the Jost function [\(5.1\)](#) is a product of character automorphic functions, and so character automorphic. That is, there is a  $C_J \in \Gamma^*$  associated with any Szegő  $J$  via

$$u(\gamma(z), J) = C_J(\gamma)u(z, J). \tag{6.3}$$

If  $C_0$  is the character associated to the fundamental Blaschke product,  $B(z)$ , [\(5.4\)](#) and the fact that  $M$  is automorphic implies

$$C_{J^{(n+1)}} = C_{J^{(n)}}C_0^{-1} \tag{6.4}$$

and so

$$C_{J^{(n)}} = C_J C_0^{-n}. \tag{6.5}$$

A fundamental fact about the map  $C$  (discussed in [16]) is that

**Theorem 6.1.** *The map  $J \rightarrow C_J$  for  $J$ 's in  $\mathcal{T}_\epsilon$ , from  $\mathcal{T}_\epsilon$  to  $\Gamma^*$ , is a homeomorphism.*

**Corollary 6.2.** *Suppose  $J$  is Szegő and  $J_\infty \in \mathcal{T}_\epsilon$  obeys [\(2.6\)](#). Then  $J_\infty$  is the unique point in  $\mathcal{T}_\epsilon$  obeying*

$$C_{J_\infty} = C_J. \tag{6.6}$$

**Sketch.** [\(2.8\)](#) implies that  $u(z, J^{(n)})/u(z, J_\infty^{(n)}) \rightarrow 1$  at points away from  $x^{-1}(\mathbb{R})$  (where it might be 0), which implies  $C_{J^{(n)}}/C_{J_\infty^{(n)}} \rightarrow 1$  which, by [\(6.5\)](#), implies  $C_J/C_{J_\infty} \equiv 1$ . Uniqueness follows from the theorem.  $\square$

We have a scheme for proving the convergence result [\(2.6\)](#) which we hope to implement in the final version of [17]. Because it shows a heretofore unknown connection between Szegő behavior and Rakhmanov's theorem, we want to describe the idea.

What can be called the Denisov–Rakhmanov–Remling theorem—namely, a corollary that Remling [39] gets of his main theorem that extends the theorem of Denisov–Rakhmanov [40] and Damanik–Killip–Simon [9] to general finite gap sets—says that any right limit of a  $J$  with  $\sigma_{\text{ess}}(J) = \Sigma_{\text{ac}}(J) = \epsilon$  ( $\Sigma_{\text{ac}}$  is the essential support of the a.c. spectrum) lies in  $\mathcal{T}_\epsilon$ . A direct proof of [\(6.6\)](#) would determine a unique orbit in  $\mathcal{T}_\epsilon$  (orbit under coefficient stripping) to which the orbit of  $J$  is asymptotic, and so prove [\(2.6\)](#).

We have a proof (whose details need to be checked) that implements this idea and we hope to use it to get a totally new proof of [Theorem 2.2](#) that does not use variational principles.

For now, our proof of [Theorem 2.2](#) in [17], following Widom [18], uses the Szegő variational approach [41]. In essence, Szegő shows  $z^n P_n(z + \frac{1}{z})$  has a limit  $D(0)D(z)^{-1}$  minimizing an  $L^2$ -norm, subject to taking the value 1 at  $z = 0$ . In our case,  $B(z)^n P_n(x(z))$  is only character automorphic with an  $n$ -dependent character (namely  $C_0^n$ ), so it does not have a fixed limit. Rather, it minimizes an  $L^2$ -norm among character automorphic functions (with a fixed but  $n$ -dependent character)—which explains why the limiting behavior is only almost periodic.

### Acknowledgments

The second author is supported in part by NSF grants DMS–0140592 and DMS–0652919.

## References

- [1] G. Szegő, *Orthogonal Polynomials*, 3rd ed., in: Amer. Math. Soc. Colloq. Publ., vol. 23, American Mathematical Society, Providence, RI, 1967. MR0000077.
- [2] T.S. Chihara, *An Introduction to Orthogonal Polynomials*, in: *Mathematics and its Applications*, vol. 13, Gordon and Breach, New York, London, Paris, 1978. MR0481884.
- [3] G. Freud, *Orthogonal Polynomials*, Pergamon Press, Oxford, New York, 1971.
- [4] B. Simon, Szegő's Theorem and its Descendants: Spectral Theory for  $L^2$  Perturbations of Orthogonal Polynomials, Princeton University Press (in press).
- [5] Ya.L. Geronimus, *Orthogonal Polynomials: Estimates, Asymptotic Formulas, and Series of Polynomials Orthogonal on the Unit Circle and on an Interval*, Consultants Bureau, New York, 1961. MR0133643.
- [6] B. Simon, *Orthogonal Polynomials on the Unit Circle, Part1: Classical Theory*, in: AMS Colloquium Publications, vol. 54.1, American Mathematical Society, Providence, RI, 2005. MR2105088.
- [7] B. Simon, *Orthogonal Polynomials on the Unit Circle, Part2: Spectral Theory*, in: AMS Colloquium Publications, vol. 54.2, American Mathematical Society, Providence, RI, 2005. MR2105088.
- [8] R. Killip, B. Simon, Sum rules for Jacobi matrices and their applications to spectral theory, *Ann. of Math.* 158 (2003) 253–321. MR1999923.
- [9] D. Damanik, R. Killip, B. Simon, Perturbations of orthogonal polynomials with periodic recursion coefficients, *Ann. of Math.* Preprint (in press).
- [10] N.S. Landkof, *Foundations of Modern Potential Theory*, Springer-Verlag, Berlin, New York, 1972. MR0350027.
- [11] T. Ransford, *Potential Theory in the Complex Plane*, in: London Mathematical Society Student Texts, vol. 28, Cambridge University Press, Cambridge, 1995. MR1334766.
- [12] B. Simon, Equilibrium measures and capacities in spectral theory, *Inverse Problems Imaging* 1 (2007) 713–772. MR2350223.
- [13] A.I. Aptekarev, Asymptotic properties of polynomials orthogonal on a system of contours, and periodic motions of Toda chains, *Math. USSR Sb.* 53 (1986) 233–260. Russian original in *Mat. Sb. (N.S.)* 125 (167) (1984) 231–258. MR0764479.
- [14] F. Peherstorfer, Orthogonal and extremal polynomials on several intervals, in: *Proc. Seventh Spanish Symposium on Orthogonal Polynomials and Applications*, J. Comput. Appl. Math. 48 (1993) 187–205. MR1246858.
- [15] V. Totik, Polynomial inverse images and polynomial inequalities, *Acta Math.* 187 (2001) 139–160. MR1864632.
- [16] J.S. Christiansen, B. Simon, M. Zinchenko, Finite gap Jacobi matrices, I, The isospectral torus, *Constr. Approx.* (in press).
- [17] J.S. Christiansen, B. Simon, M. Zinchenko, Finite gap Jacobi matrices, II, Szegő's theorem (in preparation).
- [18] H. Widom, Extremal polynomials associated with a system of curves in the complex plane, *Adv. Math.* 3 (1969) 127–232. MR0239059.
- [19] N.I. Akhiezer, Orthogonal polynomials on several intervals, *Soviet Math. Dokl.* 1 (1960) 989–992. MR0110916.
- [20] N.I. Akhiezer, Yu.Ya. Tomčuk, On the theory of orthogonal polynomials over several intervals, *Soviet Math. Dokl.* 2 (1961) 687–690. MR0131005.
- [21] Yu. Tomčuk, Orthogonal polynomials over a system of intervals on the real line, *Zap. Fiz.-Mat. Fak. i Kharkov. Mat. Obsc.* (4) 29 (1963) 93–128 (in Russian).
- [22] F. Peherstorfer, P. Yuditskii, Asymptotic behavior of polynomials orthonormal on a homogeneous set, *J. Anal. Math.* 89 (2003) 113–154. MR1981915.
- [23] F. Peherstorfer, P. Yuditskii, Remark on the paper “Asymptotic behavior of polynomials orthonormal on a homogeneous set”. [arXiv:math.SP/0611856](https://arxiv.org/abs/math.SP/0611856).
- [24] M. Sodin, P. Yuditskii, Almost periodic Jacobi matrices with homogeneous spectrum, infinite-dimensional Jacobi inversion, and Hardy spaces of character-automorphic functions, *J. Geom. Anal.* 7 (1997) 387–435. MR1674798.
- [25] P. Nevai, Orthogonal polynomials, recurrences, Jacobi matrices, and measures, in: *Progress in Approximation Theory* (Tampa, FL, 1990), in: Springer Ser. Comput. Math., vol. 19, Springer, New York, 1992, pp. 79–104. MR1240779.
- [26] D. Hundertmark, B. Simon, Lieb–Thirring inequalities for Jacobi matrices, *J. Approx. Theory* 118 (2002) 106–130. MR1928259.
- [27] R. Frank, B. Simon, T. Weidl, Eigenvalue bounds for perturbations of Schrödinger operators and Jacobi matrices with regular ground states, *Comm. Math. Phys.* 282 (2008) 199–208. MR2415477.
- [28] D. Hundertmark, B. Simon, Eigenvalue bounds in the gaps of Schrödinger operators and Jacobi matrices, *J. Math. Anal. Appl.* 340 (2008) 892–900. MR2390896.
- [29] G. Szegő, Über den asymptotischen Ausdruck von Polynomen, die durch eine Orthogonalitätseigenschaft definiert sind, *Math. Ann.* 86 (1922) 114–139.
- [30] F. Peherstorfer, P. Yuditskii, Asymptotics of orthonormal polynomials in the presence of a denumerable set of mass points, *Proc. Amer. Math. Soc.* 129 (2001) 3213–3220. MR1844996.
- [31] H.M. Farkas, I. Kra, *Riemann Surfaces*, in: Graduate Texts in Math., vol. 71, Springer, New York, Berlin, 1980. MR0583745.
- [32] A.F. Beardon, Inequalities for certain Fuchsian groups, *Acta Math.* 127 (1971) 221–258. MR0286996.
- [33] W. Burnside, On a class of automorphic functions, *Proc. London Math. Soc.* 23 (1891) 49–88.
- [34] B. Simon, A. Zlatoš, Sum rules and the Szegő condition for orthogonal polynomials on the real line, *Comm. Math. Phys.* 242 (2003) 393–423. MR2020274.
- [35] B. Simon, A canonical factorization for meromorphic Herglotz functions on the unit disk and sum rules for Jacobi matrices, *J. Funct. Anal.* 214 (2004) 396–409. MR2083307.
- [36] S.A. Denisov, On the preservation of absolutely continuous spectrum for Schrödinger operators, *J. Funct. Anal.* 231 (2006) 143–156. MR2190166.
- [37] S.D. Fisher, *Function Theory on Planar Domains*, Wiley, New York, 1983. MR0694693.
- [38] B. Simon, Representations of Finite and Compact Groups, in: Graduate Studies in Mathematics, vol. 10, American Mathematical Society, Providence, RI, 1996. MR1363490.
- [39] C. Remling, The absolutely continuous spectrum of Jacobi matrices. Preprint.
- [40] S.A. Denisov, On Rakhmanov's theorem for Jacobi matrices, *Proc. Amer. Math. Soc.* 132 (2004) 847–852. MR2019964.
- [41] G. Szegő, Beiträge zur Theorie der Toeplitz'schen Formen, *Math. Z.* 6 (1920) 167–202; *Math. Z.* 9 (1921) 167–190.